

Mio-x AHRS

Attitude and Heading Reference System

Engineering Specifications

Rev. G 2012-05-29

General Description

Mio-x AHRS is a tiny sensomodule consists of 9 degree of freedom motion sensors (3 accelerometers, 3 gyroscopes, 3 magnetometers) and an attitude and heading processor. With the size of 23mm × 16mm × 3mm, it provides real time, Kalman Filter optimized static and dynamic attitude and heading angles with eliminated drift, as well as sensor data. Also it features ultra low power consumption, typical 0.13W. It is especially designed for applications that have critical demand on size and power consumption.

Factory calibrated for offset, scale factor, cross-axis sensitivity and misalignment of each axis of sensors, temperature compensated offset for reduced bias drift.

Applications

- Human motion capture
- R/C hobby planes and models
- Smart toys and robots
- Car navigation
- Platform stabilization
- Consumer electronics
- Monitoring device

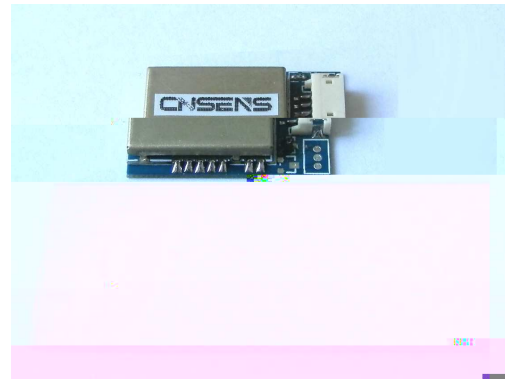

Features

- Integrated 9 degree of freedom motions sensors and temperature sensor
- Real time 3D attitude and heading data output at 50Hz
- Bias tracking algorithm to eliminate drift
- Special fuzzy algorithm to reduce the linear acceleration's impact on attitude calculation
- Ultra compact and low power
- User friendly PC demo software
- Non-calibration, or factory calibration at 25°C or 0°C~50°C available under request

Typical Specifications^{Note}

Heading	
Range	±180 °
Accuracy (RMS) @ 25°C	< 3°
Resolution:	< 0.1 °
Attitude	
Range: Roll , Pitch	±180 °, ±90 °
Accuracy: (RMS) @ 25°C	< 2° (Dynamic), <0.25° (Static)
Resolution:	< 0.1 °
Angular Rate	
Range: Yaw, Pitch, Roll	±2000 °/sec
Zero Rate Bias Stability: @ 25°C	< 200 °/hr
Resolution	< 0.1 °/sec
Bandwidth:	40 Hz
Acceleration	
Input Range:	±2 g,
Resolution:	< 10 mg
Bandwidth:	37 Hz
Magnetometer	
Input Range:	±4gauss
Resolution:	< 2.5 mgauss
Bandwidth:	50 Hz
Electrical and environment	
Power supply:	3.3-5VDC, 26mA Typical.
Interface:	UART (3.3V LVTTTL) and USB (EVM).
Working temperature range:	-20°C~85°C

Mechanical Dimensions Unit in mm

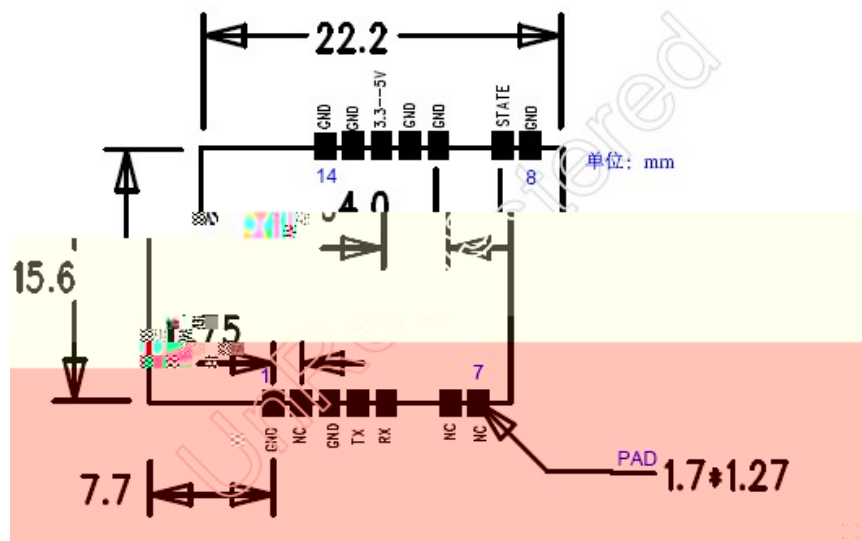

Packet protocol

Header 1	Header 2	Class	ID	Length	Payload	CheckSum

Note:

- Little-endian data mode
- Header1 and header2 are fixed 'T', 'M' as headers;
- Class is the major type of the packet, ID is the detailed type ,depending on the packet types.
- Length: Payload length
- Payload: Data
- CheckSum: CRC check

For now Mio-1 AHRS has only one type of packet, Class is 0x0F, ID is 0x01, detailed description:

Byte sequence	Contents	Number of bytes	Data type	Description
Header 1		1	8 bit unsigned int	'T'
Header 2		1	8 bit unsigned int	'M'
Class		1	8 bit unsigned int	0x0F
ID		1	8 bit unsigned int	0x01
Length		2	16bit unsigned int	0x31(Payload's length)
Payload	Including the following items			
	Flags	1	8 bit unsigned int	Reserved
	Roll	4	Single precision float	Roll, unit in

				degree(+/-180)
	Pitch	4	Single precision float	Pitch, unit in degree(+/-90)
	Yaw	4	Single precision float	Heading, unit in degree(+/-180)
	GyroX	4	Single precision float	Unit in deg/s
	GyroY	4	Single precision float	Unit in deg/s
	GyroZ	4	Single precision float	Unit in deg/s
	AccX	4	Single precision float	Unit in g
	AccY	4	Single precision float	Unit in g
	AccZ	4	Single precision float	Unit in g
	MagX	4	Single precision float	No unit
	MagY	4	Single precision float	No unit
	MagZ	4	Single precision float	No unit
Checksum		2	16bit unsigned int	From class to the end of payload's CRC16 check bytes

AIR MOUSE PROTOCOL

Byte sequence	Contents	Number of bytes	Data type	Description
Header 1		1	8 bit unsigned int	'T'
Header 2		1	8 bit unsigned int	'M'
Class		1	8 bit unsigned int	0x0F
ID		1	8 bit unsigned int	0x01
Length		2	16bit unsigned int	0x13(Payload's length)
Payload	Including the following items			
	Flags	1	8 bit unsigned int	Reserved
	X value	4	Single precision float	Value of X
	Y value	4	Single precision float	Value of Y
	Yaw	4	Single precision float	Heading, unit in degree(+/-180)
Checksum		2	16bit unsigned int	From class to the end of payload's CRC16 check bytes

PC software

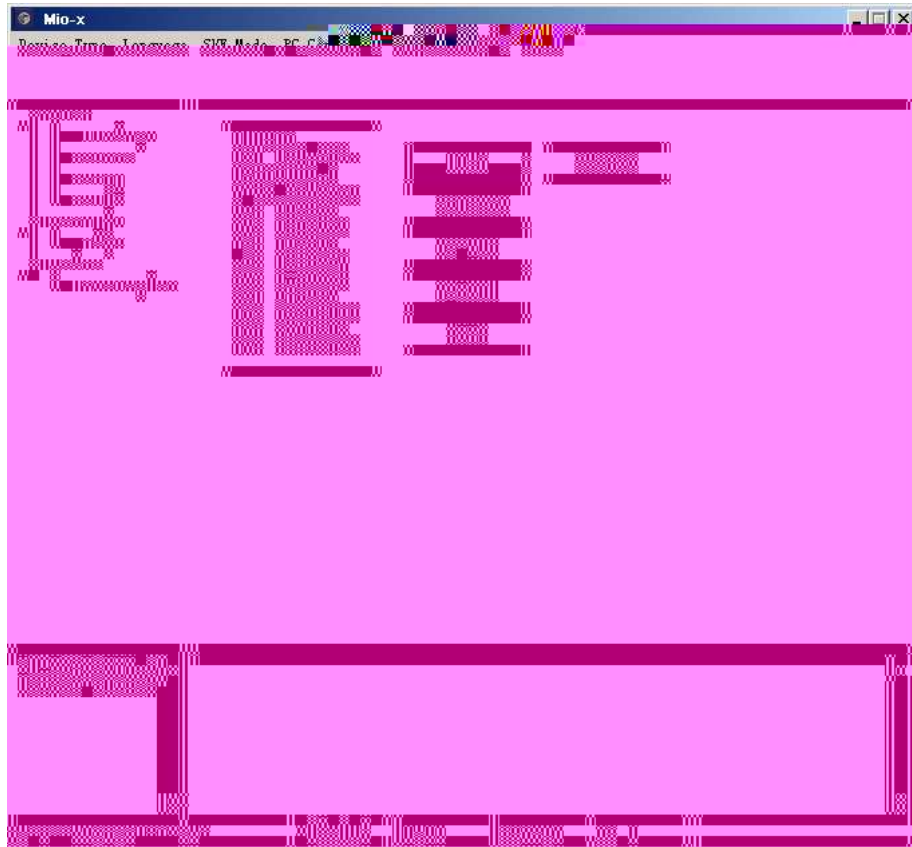

Main interface

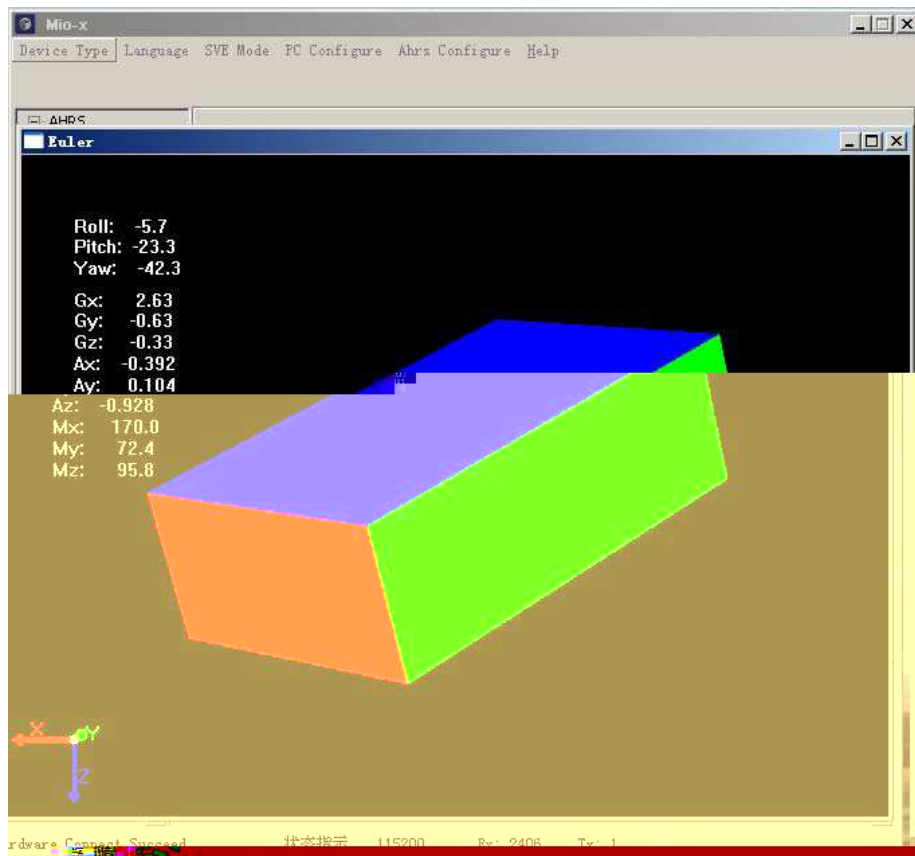

Euler angle view



Scope view

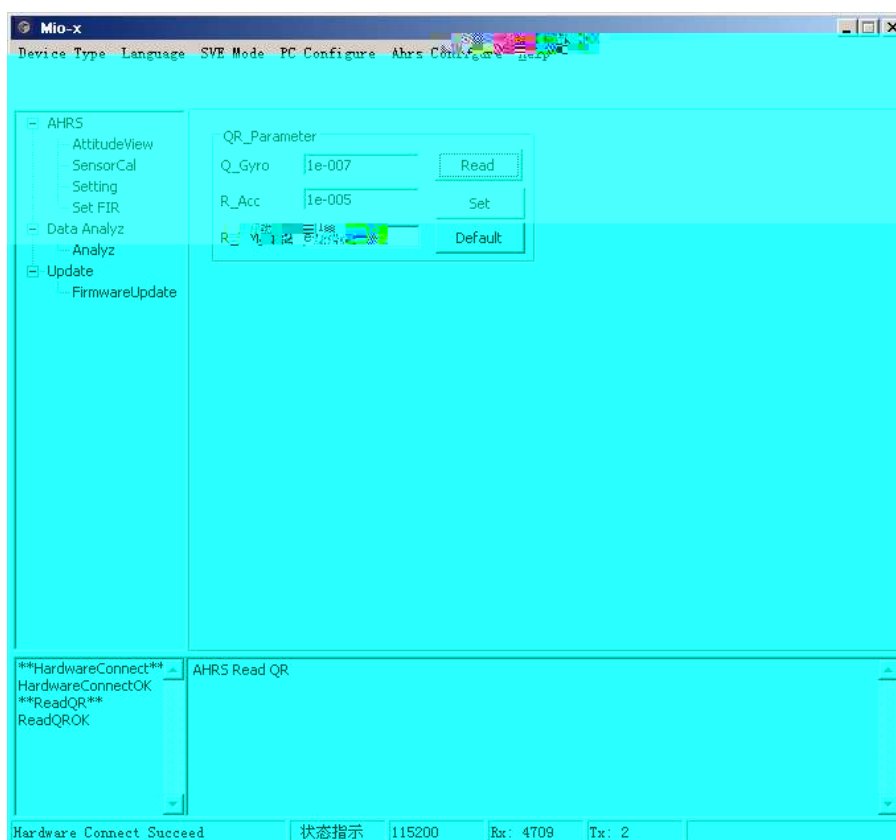

Kalman Filter tuning

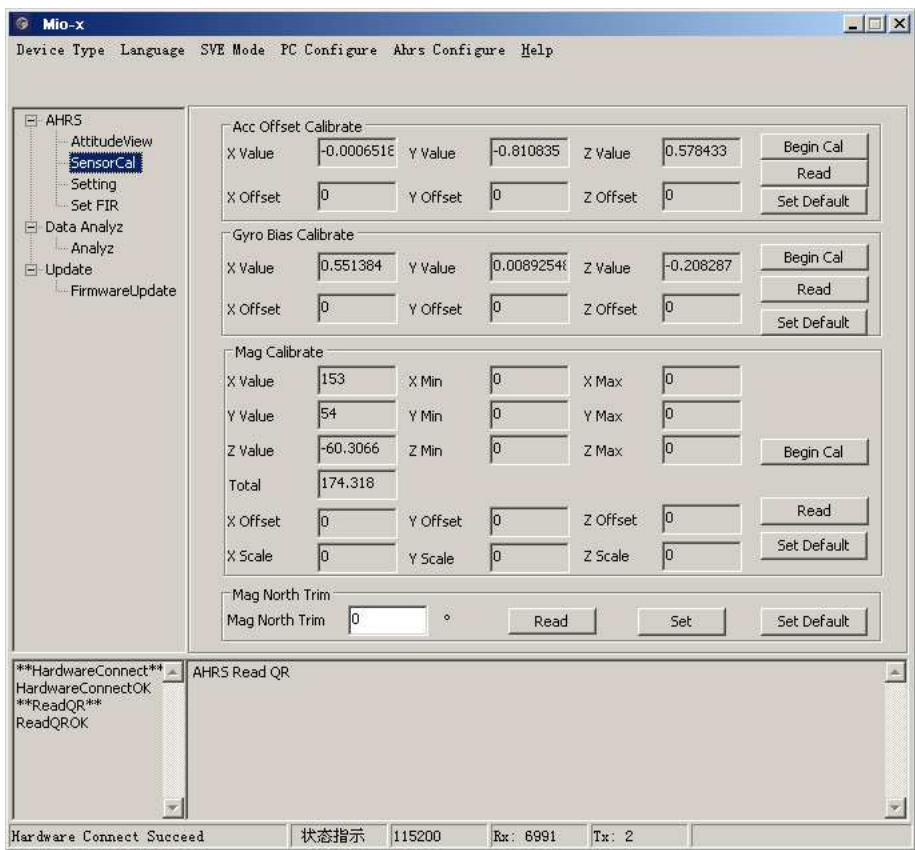

Manual calibration of magnetic sensor